

The ideal solution for all
types of room and use.



**OUTSIDE AIR FLOW
SUPPLY ELEMENTS**

EXTRACT AIR ELEMENTS

Alongside the fan, extract air elements form the basis for demand-optimised function in central ventilation systems. By equipping them with varying air flow volumes or time, motion and moisture control fulfil, the innovative extract air elements (AE) from Helios are ideal for fulfilling requirements in this area.

501^{on}

**FILTER ELEMENTS
ATTENUATORS**

Preliminary filter elements prevent the build-up of fat and dust on extract air elements and poppet valves, as well as in the ducting system.

Slide-in cross-talk sound attenuators reduce the noise from the ducting system and telephony from one residential unit to another.

504

**VENTILATION AND
POPPET VALVES**

The ventilation valves (DLV), the design of which has won several awards, fit in beautifully and inconspicuously in any home atmosphere.

Conventional poppet valves for exhaust air and supply air operation are ideally suited for various industrial and commercial applications.

506^{on}



Outside air elements are the most efficient way of ensuring the scheduled supply of air in compliance with the standards. The number, size and placement of the elements are to be defined such that the required volume can be dosed and can flow in without causing a draught. According to DIN 1946-6, it should be taken into account when sizing the extract air elements that an indoor pressure is not more than around 8 Pa below the outside pressure.

512^{on}



Selection

Extract air elements only optimally perform the required function when they are coordinated with the task. Use the chart below to select the correct extract element where the selection depends on volume and application. There is a choice of element designs, with constant air flow volume with and without on demand ventilation, with timer, motion or humidity controlled operation.

Bathroom 		WC 		Kitchen 	
Type	Ref. no.	Type	Ref. no.	Type	Ref. no.
Constant air flow volume controller, self-adjusting					
AE 45*	2031	AE 30*	2030	AE 75*	2033
Two air flow volumes (std. and demand-based ventilation), constant air flow control, self-adjusting					
AE GB 20/75*	2036	AE GB 15/30*	2035	AE GB 45/120*	2038
Two air flow volumes with electrical timer (without constant air flow volume control)					
AE GBE 30/60*	2047	AE GBE 15/30*	2044	AE GBE 45/120*	2048
Two air flow volumes with electrical timer and motion sensor, page 503					
		AE B 15/30*	2055	(without constant air flow control)	
Humidity controlled with variable, limited air flow volume, page 503					
AE Hygro 10/45*	2049				
Humidity controlled with electrically controlled on demand ventilation, page 503					
AE Hygro GBE 5/40/75*	2053			AE Hygro GBE 10/45/120*	2054
With filter and air flow volume adjustment					
AE FV 125	9478			AE FV 125	9478

* Air flow volume in m³/h

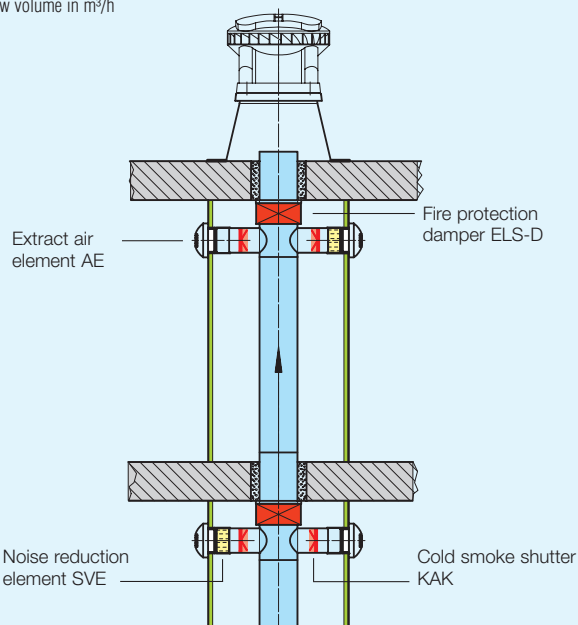

Acoustic data for extract air elements of series AE

The following sound levels are relevant for the extract air elements:
 – Sound power level for permanent air flow (L_w in dB (A))
 – Sound insulation between ducting system and ventilated room ($D_{n,e}$ in dB (A)).

This sound data is specified in the respective type table. They were measured according to the standard EN 13141.

The sound insulation value can be increased by using attenuator "AESD" or "AESE" (accessories), which is to be positioned and simply inserted behind the extract air element.

Cross talk attenuators are available for further noise reduction (p. 505).

Operation

Extract air elements with self adjusting constant air flow volume controllers are the ideal components for extraction in kitchens, bathrooms and toilets for central ventilation systems in houses.

Advantages

- Constant air flow volume between 40 and 160 Pa.
- No need for adjustment or balancing of the system.
- Attractive design.
- High quality construction in an aerodynamic shape with low sound levels.
- The cover and optimised height of the inlet nozzle offer an airtight seal against the wall.
- Easy cleaning without a risk of air flow volume change.

Design

Extract air element with mounting ring, ready to install, made of white polymer to be inserted in ducts with a nominal diameter of 125 mm. A rubber seal on the mounting ring to avoid leakage. As a result, the discolouration of decor is minimised.

Function

Ensures constant air flow volume under different pressure conditions between 40 and 160 Pa.

Delivery

Supplied as one element incl. mounting ring in separate poly bag.

Accessories

- Attenuator AESD to be inserted behind the element (Ref. no. 2059)
- Adapter filter element VFE 70 (Ref. no. 2552).

AE

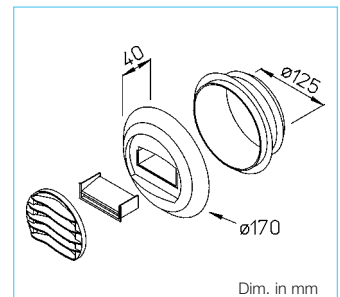

Dim. in mm

Installation

Suitable for wall and ceiling installation. The mounting ring, to be fixed via screws on duct or wall openings and the extract air element to be inserted. For an equal inlet and outlet air flow a straight duct of at least 300 mm is required.

Air flow volume performance curve AE

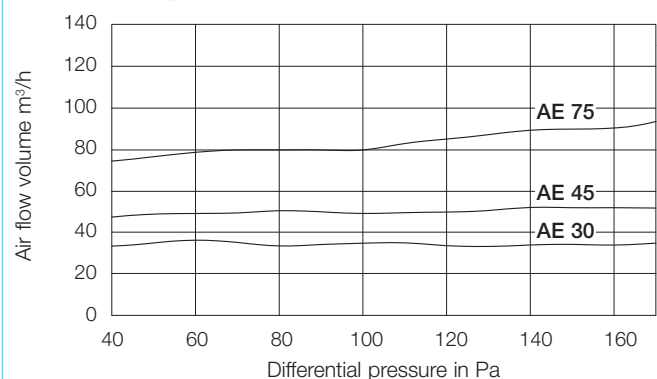

Type	Ref. no.	Sound power level L_w in dB (A)			Sound insulation $D_{n,e}$ in dB (A)	
		100 Pa	130 Pa	160 Pa	without AESD	with AESD
AE 30*	2030	30	33	36	60	64 ¹⁾
AE 45*	2031	33	34	37	56	63 ¹⁾
AE 75*	2033	35	36	39	57	64 ¹⁾

¹⁾ Equipped with attenuator AESD (accessories) * Air flow volume in m³/h

Operation

Extract air elements for two air flow volumes (basic and boost) with self adjusting constant air flow volume controller are the ideal components for extraction in kitchens, bathrooms and toilets for central ventilation systems in houses.

Advantages

- Two air flow volumes for standard and demand-based ventilation.
- Constant air flow volume between 40 and 160 Pa.
- No need for adjustment or balancing of the system.
- Attractive design.
- High quality construction in an aerodynamic shape with low sound levels.
- The cover and optimised height of the inlet nozzle offer an airtight seal against the wall.
- Easy cleaning without a risk of air flow volume change.

Function AE GB

The self adjusting air flow volume limiter keeps the adjusted nominal air flow volume (between 40 and 160 Pa) constant (see performance curve). Two control steps allow for standard and demand-based ventilation. On/off switching of high air flow volumes manually via pull cord.

Design (AE GB, AE GBE)

Extract air element with mounting ring, ready to install, made of white polymer to be inserted in ducts with nominal diameter of 125 mm. The rubber seal on the mounting ring avoids leakage of air. As a result, dis-colouration of the decor is minimised.

AE GB

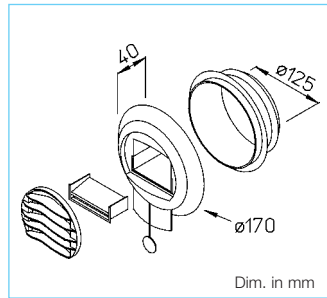

AE GBE

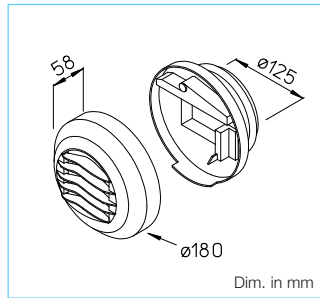

Operation

Extract air device with electric timer for two air flow volumes (standard and demand-based ventilation). Ideal components for extraction in kitchens, bathrooms and toilets for central ventilation systems in houses.

Advantages

- Two air flow volumes for standard and demand-based ventilation e.g. via on-site switch.
- No need for adjustment or balancing of the system.
- Attractive design.
- High quality construction in an aerodynamic shape with low sound levels.
- The cover and optimised height of the inlet nozzle offer an airtight seal against the wall.
- Easy cleaning without a risk of air flow volume change.

Function AE GBE

The basic air flow is increased to the higher level of air flow via a switch on-site (by others). After 30 minutes – regardless of the position of the switch on-site – it automatically returns to “standard ventilation”. 230 V, AC 0.5/3 W, IP X1

Installation (AE GB, AE GBE)

AE GB for wall, AE GBE also suitable for ceiling installation. The mounting ring, to be fixed via screws on duct or wall openings and the extract air element to be inserted. For an equal inlet and outlet air flow a straight duct of at least 300 mm is required.

Accessories

- Attenuator:
AE GB: AESD, Ref. no. 2059
AE GBE: AESE, Ref. no. 2058
- Adapter filter element
AE GBE: VFE 90, Ref. no. 2553 obstructs grease and dust deposits on extract air elements and in ducting.

Delivery

Supplied as one element incl. mounting ring in separate Poly-bag.

Upon request

Type AE FV 125 Extract air element filter and air flow volume adjustment, Ref. no. 9478

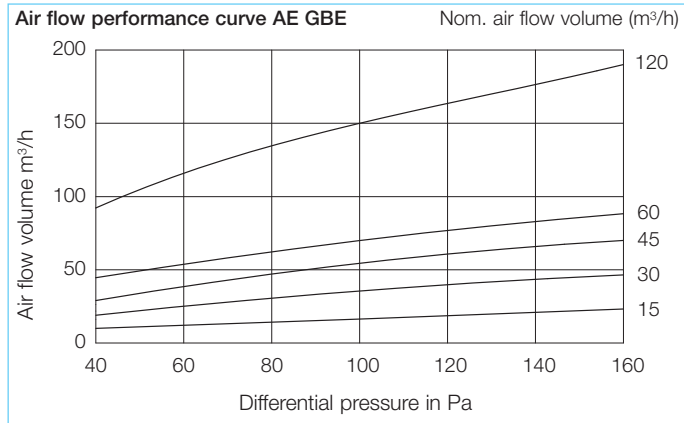
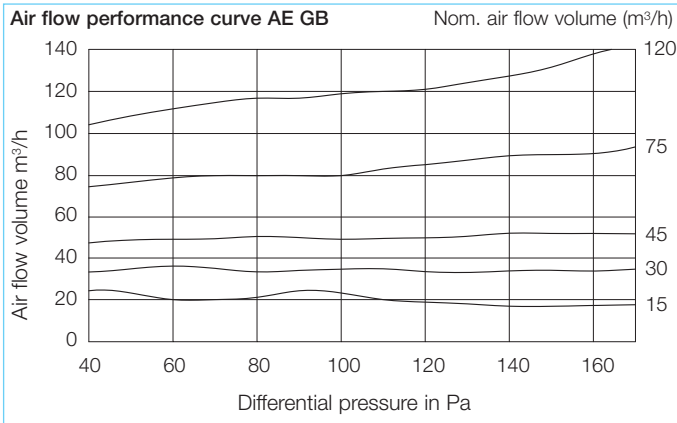

Ordering data		Sound power level ²⁾ L _w in dB (A)			Sound insulation D _{n,e} in dB (A)	
Type	Ref. no.	100 Pa	130 Pa	160 Pa	without AESD	with AESD
AE GB 15/30*	2035	27	31	34	60	64 ¹⁾
AE GB 20/75*	2036	27	30	33	57	64 ¹⁾
AE GB 45/120*	2038	33	34	37	56	63 ¹⁾

¹⁾ Equipped with attenuator AESD (accessories) ²⁾ Values are valid for standard ventilation
* Air flow volume in m³/h

Ordering data		Sound power level ²⁾ L _w in dB (A)			Sound insulation D _{n,e} in dB (A)	
Type	Ref. no.	100 Pa	130 Pa	160 Pa	without AESD	with AESD
AE GBE 15/30*	2044	30	33	36	60	64 ¹⁾
AE GBE 30/60*	2047	27	30	33	57	64 ¹⁾
AE GBE 45/120*	2048	29	32	35	57	62 ¹⁾

¹⁾ Equipped with attenuator AESE (accessories) ²⁾ Values are valid for standard ventilation

Operation

Extract air device with motion sensor and timer for two air flows (standard and demand-based ventilation). Ideal for extraction in kitchens, bathrooms and toilets for central ventilation systems in houses.

Advantages

- Two air flow volumes for standard and demand-based ventilation via integrated motion sensor.
- No need for adjustment or balancing of the system.
- Attractive design.
- High quality construction in an aerodynamic shape with low sound levels.
- The cover and optimised height of the inlet nozzle offer an airtight seal against the wall.
- Easy cleaning without a risk of air flow volume change.

Design

Extract air element with mounting ring, ready to install, made of white polymer to be inserted in ducts with nominal diameter of 125 mm. The rubber seal on the mounting ring avoids air leakage. As a result, discolouration of the decor is minimised.

Function AE B

The basic air flow is to be increased to on demand air flow via an integrated motion sensor. After 30 minutes it automatically returns to "standard ventilation". Electrical supply through three batteries (on site, model LR 03, 1.5 V, operational life span approx. 18 months.).

AE B – with motion sensor

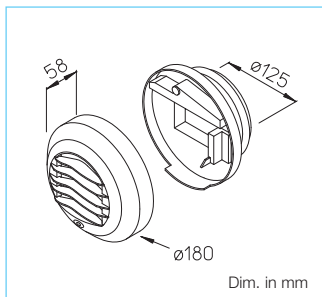

■ **Delivery and installation**
See description Type AE GB.

Accessories

- Attenuator AESE to be inserted behind the element (Ref. no. 2058).

AE Hygro – humidity controlled

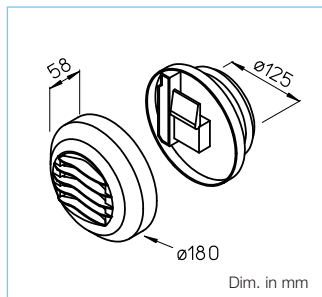

■ **Design, delivery and installation**
See description Type AE GB.

Accessories

- Attenuator AESE to be inserted behind the element (Ref. no. 2058).
- Adapter filter element VFE 90 for installation in front of the element (Ref. no. 2553).

Operation

The humidity controlled extract air elements allow a variable air flow volume depending on the relative humidity. They are suitable for the operation control of extract air volumes in bathroom and kitchen for ventilation systems in houses.

Advantages

- Automatically controlled air flow volume depending on the relative humidity between minimum and maximum limits.
- No need for adjustment or balancing of the system.
- Attractive design.
- High quality construction in an aerodynamic shape with low sound levels.
- The cover and optimised height of the inlet nozzle offer an airtight seal against the wall.
- Easy cleaning without a risk of air flow volume change.

Function AE Hygro

The air flow volume is automatically controlled depending on the relative humidity between minimum and maximum limits. Achieving the defined trickle air flow at Δp of 80 Pa depending on the relative humidity. No need for electric connection.

Additional function AE Hygro GBE

The basic air flow is increased to the higher level of air flow via a switch on-site (by others). After 30 minutes – regardless of the position of the switch on-site – it automatically returns to "standard ventilation".

230 V, AC 0.5/3 W, IP X1

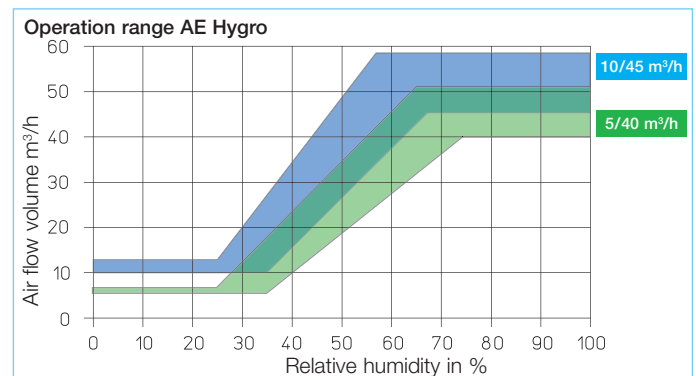
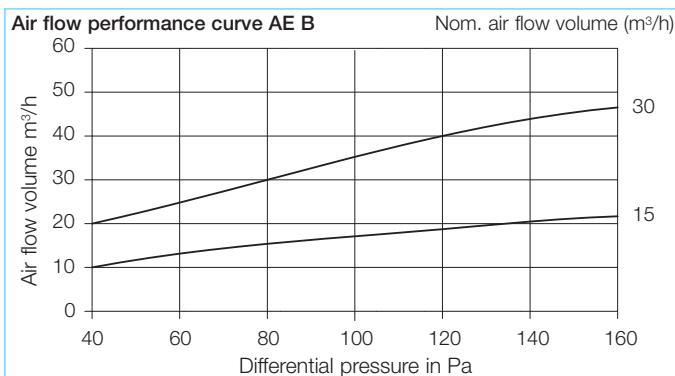

Ordering data		Sound power level ²⁾ L _w in dB (A)			Sound insulation D _{n,e} in dB (A)	
Type	Ref. no.	100 Pa	130 Pa	160 Pa	without AESE	with AESE
AE B 15/30*	2055	20	25	28	60	64 ¹⁾

¹⁾ Equipped with attenuator AESE (accessories) ²⁾ Values are valid for standard ventilation

Ordering data		Sound power level ²⁾ L _w in dB (A)			Sound insulation D _{n,e} in dB (A)	
Type	Ref. no.	100 Pa	130 Pa	160 Pa	without AESE	with AESE
AE Hygro 10/45*	2049	29	32	35	57	61 ¹⁾
AE Hygro GBE 5/40/75 ³⁾ *	2053	28	31	34	56	64 ¹⁾
AE Hygro GBE 10/45/120 ³⁾ *	2054	29	32	35	56	62 ¹⁾

¹⁾ Equipped with attenuator AESE (accessories)

²⁾ Values for standard ventilation

³⁾ For the performance curve of on demand ventilation see AE GBE left page * Air flow vol. in m³/h

ABV 100

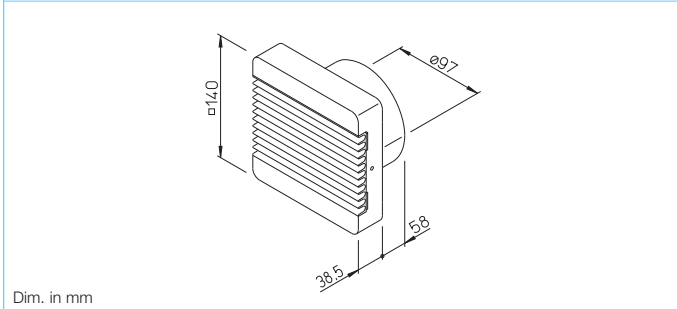

Dim. in mm

VFE

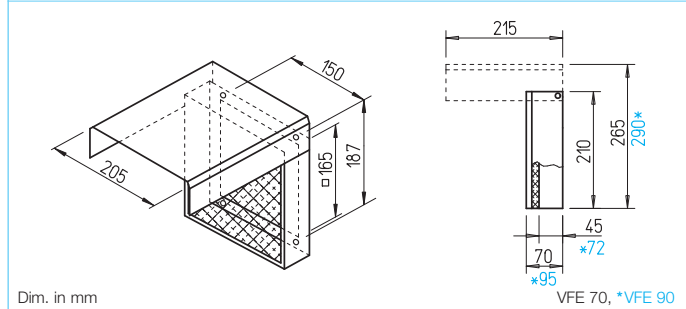

Dim. in mm

VFE 70, *VFE 90

AbluVent ABV 100

Can be used in central ventilation systems in accordance with DIN 18017-3 with variable air flow volumes. Demand-regulated ventilation, e.g. for bathrooms and toilets without windows. All elements in the system must have the same design. Made of high quality polymer, colour: White.

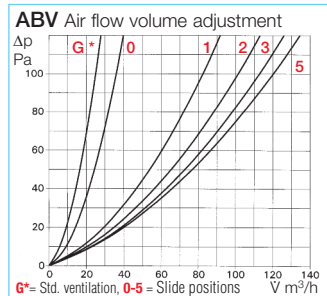

Function

AbluVent is operated via a light switch. The louvres open when the room is in use. Standard ventilation is provided when the room is not in use, a low air flow is extracted when the louvres are closed.

The diagram above shows the air flow in relation to the setting and negative pressure.

Advantages

- Energy saving.
- Low cost.
- Quick installation.
- Always an optimum solution.
- Delayed closure of approx. 5 minutes.
- Stepless adjustment of air flow volume.
- Noiseless operation.
- Changeable filter to keep duct system clean.

Air flow volume

The opening pitch of the louvres can be set stepless between 15 – 80 degrees (covered, inside fascia panel).

Technical data – connection

The unit is operated by a standard on/off switch, ideally combined with a light switch. Supply voltage: ~220/240 V, 3 W. Double insulated, interference-free, protected to IP 44. Casing: polymer, alpine white. The thermal metal shutter works with a short delay opening (approx. 30 sec.) and closing of (approx. 5 min.).

Type ABV 100 Ref. no. 0452

Accessories

Type ELF/ABV Ref. no. 6906
Spare filter mats.
Contents = 5 pcs.

Adapter filter element VFE

Simple and cost effective solution for filtering greasy, contaminated room air. To be installed in front of extract air elements or poppet valves.

Operation

Filter element to cover air vents and prevent dirt deposits from poppet valves, extract air elements and connected ducting. Ideal for use in the kitchen with a central ventilation system in line with DIN 18017.

Advantages

- Prevents grease and dust deposits from extract air elements or poppet valves and connected ducting.
- Filter replacement in a few easy steps.
- The permanent filter can be cleaned in a dishwasher.
- Discreet design in pleasant white.
- Simple installation via four screws.
- Hinders possible contamination areas.
- Less maintenance cost of ducting through longer cleaning periods

Casing

Robust casing made of galvanised sheet steel, white, powder coated polymer. The fascia panel is pivotable at 90° and prevents the view into the filter and contamination area.

Filter

Dimensionally stable aluminium filter fabric with 324 cm² free filter area and aluminium frame.

VFE Pressure loss clean condition

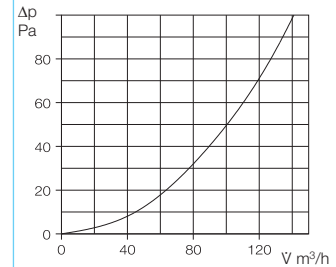

Installation

Suitable for wall and ceiling installation. Simply fixed with four screws. Elongated slot-fixing holes ensure easy positioning. To be fixed directly over the installed extract air element (max. outer Ø 175 mm). Fascia panel is hinged at 90°; for easy filter removal and a space between the upper edge of the casing and the ceiling (see drawing) is necessary.

Delivery

Each element including installation accessories is packed separately.

Delivery range

Type VFE 70 Ref. no. 2552

Suitable for extract air elements with max. 70 mm installation depth such as AE, MTVA, KTVA, BTV, BTK.

Type VFE 90 Ref. no. 2553

Suitable for extract air elements with max. 90 mm installation depth such as e.g. AE GBE, AE Hygro.

Accessories

Type ELF/VFE Ref. no. 2554

Spare air filter, suitable for the types VFE 70 and VFE 90. Contents = 2 pcs.

ETS



Installation example cross talk attenuator ETS (sliced)

Surprisingly simple and cost effective solution to reduce noise transmission in central ventilation systems. Easy installation direct into ducting behind the air valve.

Advantages

- Optimum solution for the prevention of noise transmission in ventilation ducting.
- Excellent attenuation figures (see diagram).
- Simple installation by inserting into duct behind the air valve.
- Virtually no additional resistance to the system, as the resistance value is below the setting value of the valve.
- Minimising system costs by using cost effective ducting.
- Can be used with any brand of valves.

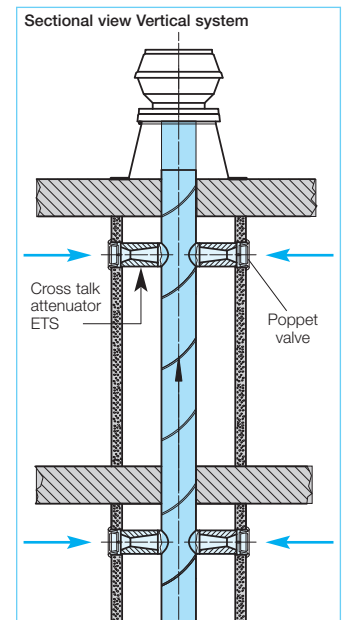
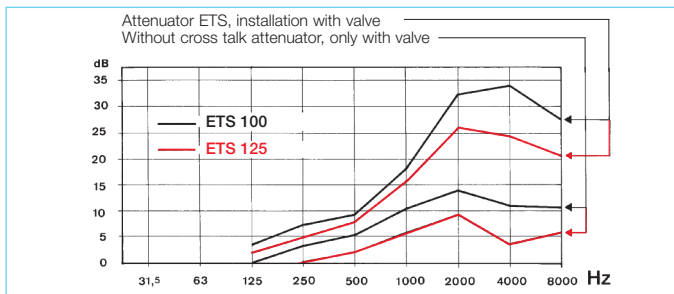
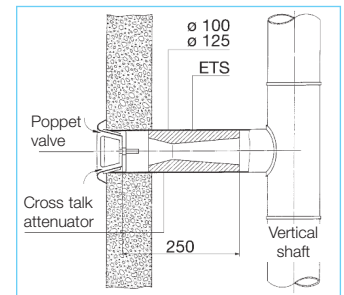
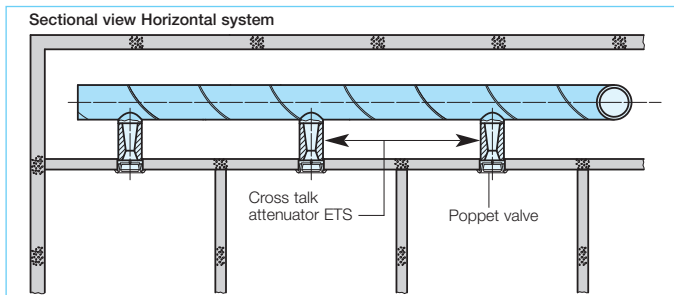

Delivery range

Type ETS 100 Ref. no. 4521
Nominal duct Ø 100 mm

Type ETS 125 Ref. no. 4522
Nominal duct Ø 125 mm

Attenuation figure

The attenuation figure can be doubled if you have two facing rooms where both have an ETS attenuator in the ducting.

Material

Flexible polyurethane foam with improved reaction in case of fire, complies with DIN 4102, class B1, UL-94-HF 1, MVSS 302 among others.



Operation

For supply air operation in all rooms without special fire protection requirements. Ideal for wall installation close to the ceiling with the air flow directed into the room.

Advantages

- Elegant, square casing made from high-quality polymer.
- Air cone evenly streams to the centre of the room.
- Includes mechanically adjustable volume controller for adjusting the ventilation system. Accessible by removing the casing, with location markers (stages 0 – 9, see diagram).
- Casing can be removed without tools for the simple cleaning of the air-exposed valve parts.
- Sealing ring on spigot for precise positioning and sealing in the ducting, prevents discolouration of the wall.
- Fixing holes in casing base for secure fixation.

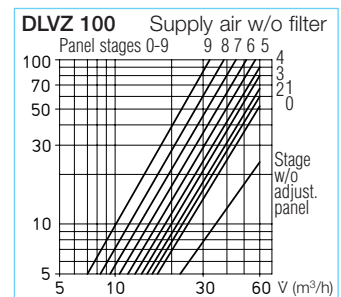
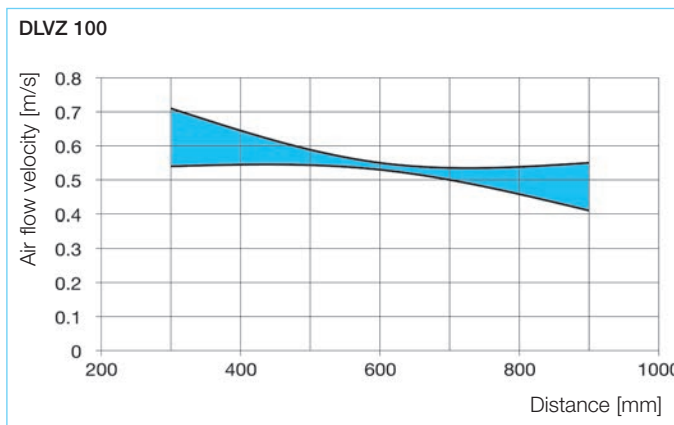

Design

Casing design made from white, impact-resistant polymer.

- When adjusting the entire system, adjust any air volume settings.
- Upper part of casing attachable without tools.

Delivery

Valves individually packaged in polybag, including setting control (mountable if necessary) as well as installation and operating instructions.

Performance data

The diagrams provide an overview of the air volumes and pressure losses for different volume controller settings, as well as the flow velocity of the out-flowing air at 30 m³/h in relation to the valve distance.

Installation

- Mount volume controller if necessary. Pre-set air volume according to diagram.
- Position casing base in ventilation duct and fix to the wall.

Ordering data	
Type	DLVZ 100
Ref. no.	3040
Dimensions in mm	
∅ C	100
A	135
B	135
D	20
Weight in g	150

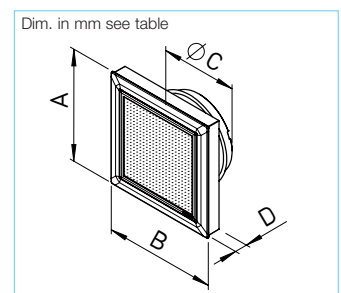

DLV



Operation

For supply and extract air operation in all rooms without special fire protection requirements. Ideal for ceiling installation.

Advantages

- Elegant, square casing made from high-quality polymer with covered air intake and discharge area.
- Precise air volume adjustment by turning the elegant front panel in 90° stages, with location markers for adjusting the ventilation system.
- Integrated filter exchangeable without tools and without risk of changing the setting.
- Selected air volume setting can be locked.
- Minimum air volume also ensured for fully closed air volume setting. Full closure only by nur irreversibly removing the minimum air volume stop.
- Front panel can be removed without tools, with adjustment mechanism and filter holder for the simple cleaning of the air-exposed valve parts.
- Sealing ring on spigot for precise positioning and sealing in the ducting.
- Fixing holes in casing base for secure fixation to the ceiling.

Accessories

Replacement air filter class G2
Contents: 5 pcs.

Type ELF-DLV 100 No. 3042

Type ELF-DLV 125 No. 3058

DLV 100 – DLV 125

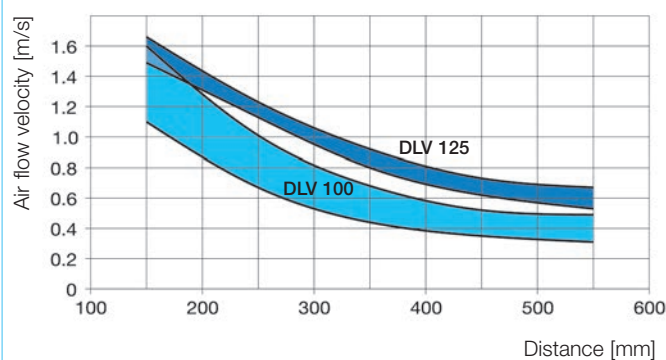

Design

Casing design made from white, impact-resistant polymer. Elegant square appearance with closed front panel.

Delivery

Valves individually packaged in polybag, including G2 filter, installation and operating instructions.

Installation

- Place G2 filter in the filter holder.
- Pre-set air volume according to diagram.
- Position casing base in ventilation duct and fix to the ceiling.

- When adjusting the entire system, adjust any air volume settings.
- Front panel with adjustment mechanism and filter holder can be attached without tools.

Performance data

The diagrams provide an overview of the air volumes and pressure losses for different front panel settings, as well as the flow velocity of the outflowing air at 30 m³/h (DLV 100) or 60 m³/h (DLV 125) in relation to the valve distance.

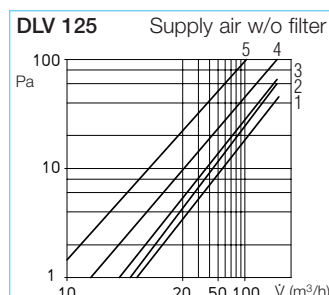
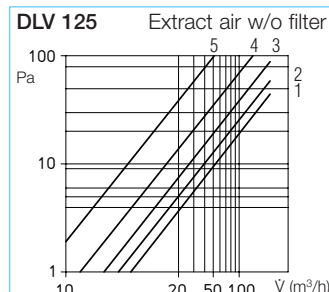
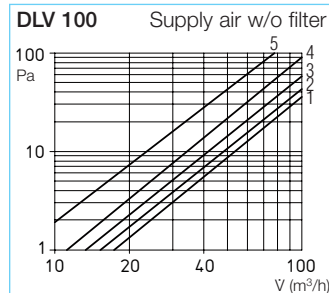
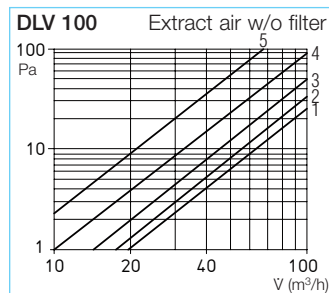

Ordering data

Type	DLV 100	DLV 125
Ref. no.	3039	3049
Dimensions in mm		
Ø C	100	125
A	135	176.5
B	135	176.5
D	10-30	15-30
Weight in g	150	210

Dim. in mm see table

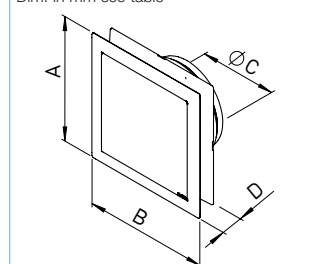

MTVA



■ Operation

For air extract in any room especially where ventilation system components of non flammable materials are required. Suitable for low and high air flow speed. Low noise characteristic.

■ Advantages

- Technically advanced design, aerodynamically shaped for low sound levels.
- Large cover with optimised height of the inlet ring avoids marking of decor.
- Quick mounting in ceiling and wall without tools.
- Plaster and difference compensation for unevenness, differences in diameter or ducting that has been too deeply plastered.
- Spring mounting clamp offers a direct insertion in ducts or walls up to approx. 20 mm size without an additional mounting ring.

■ Design

Metal construction protected against corrosion by a high quality epoxy paint in white. The foam strip fitted around the valve provides an air tight connection avoiding air leakage and dis-colouration around the valve.

■ Delivery

Each valve is separately supplied in polybag.

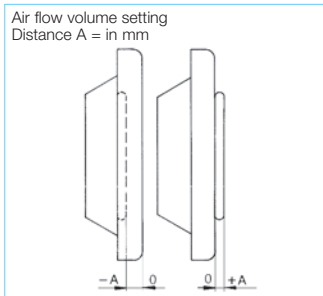

■ Accessories

For installation in ducting, walls or thin panels, a mounting ring may be required (see table).

■ Installation

Set valve to required air flow volume according to the diagram. The distance 'A' is given in mm from the 0 point. Then simply press valve into wall or ducting.

■ Performance data

These diagrams show the relationship between air flow volumes, resistances and sound levels at various adjustments of the distance "A" in mm.

MTVA 125

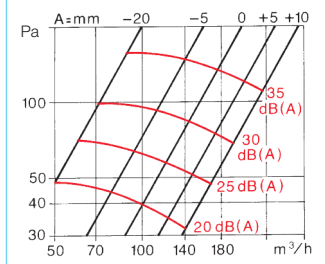

MTVA 75/80

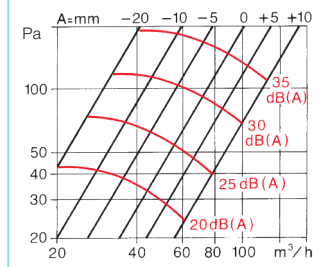

MTVA 160

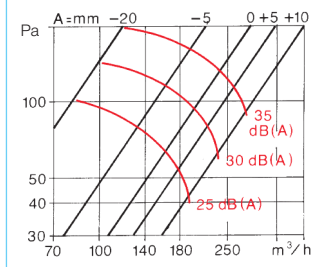

MTVA 100

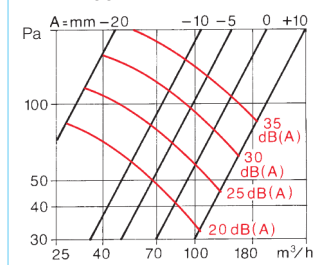

MTVA 200

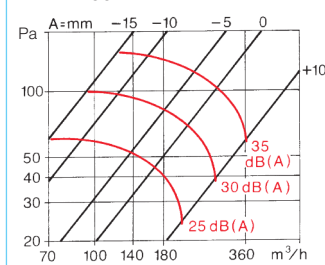

Ordering data					
Type	MTVA 75/80	MTVA 100	MTVA 125	MTVA 160	MTVA 200
Ref. no.	8868	8869	8870	8871	8872
Dim. in mm					
Ø A	73 – 85	95 – 105	120 – 130	150 – 165	195 – 205
Ø B	108	135	160	195	230
C	15	15	15	15	18
D	58	59	60	58	63
Weight in g	150	190	255	340	450
Mounting ring					
Type	EBR 75/80	EBR 100	EBR 125	EBR 160	EBR 200
Ref. no.	0952	0953	0954	0955	0956
for DN (mm)	75/80	100	125	150/160	200

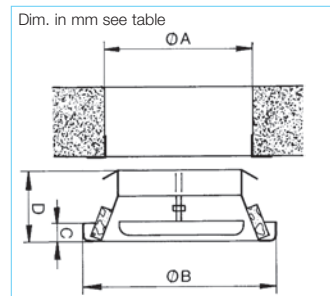

KTVA



■ Operation

For air extraction with high and low air flow speeds or resistances.
For all rooms without special fire protection requirements.

■ Advantages

- Installation without tools in seconds.
- High noise attenuation through built-in attenuator in fan.
- High quality anti static polymers suitable for temperatures up to +100 °C.
- Using a mounting ring avoids dis-colouration of surrounding decor.
- Plaster and difference compensation for unevenness, differences in diameter or ducting that has been too deeply plastered.
- Spring fit connector allows direct installation in ducting or wall with a minimum thickness of approx. 20 mm without an additional mounting ring.

■ Design

Aerodynamically shaped made from impact resistant white polymers. Adjustable air flow via rotating valve plate (volume throughput see diagram).

■ Delivery

Each valve is individually supplied in polybag.

■ Accessories

For installation in ducting, walls or thin panels, a mounting ring may be required (see table).

■ Installation

Set valve to required air flow volume according to the diagram through core revolutions then simply press valve into wall or ducting.

■ Performance data

These diagrams show the relationship between air flow volumes, resistances and sound levels at various core openings.

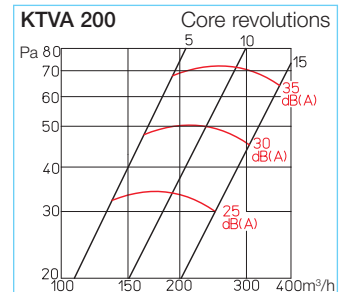
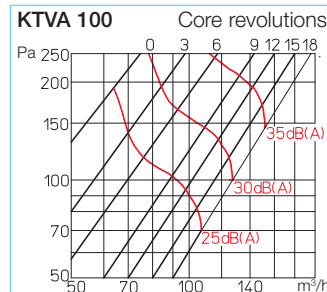
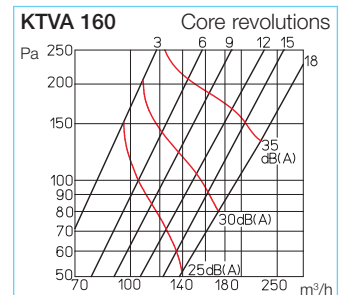
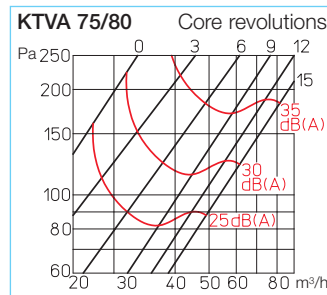
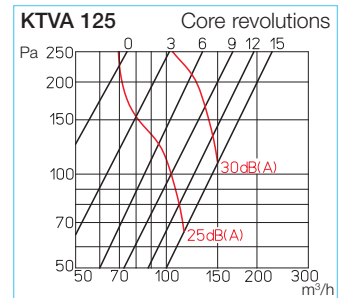

Ordering data					
Type	KTVA 75/80	KTVA 100	KTVA 125	KTVA 160	KTVA 200
Ref. no.	0940	0941	0942	0943	0944
Dim. in mm					
Ø A	73 – 85	95 – 105	120 – 130	150 – 165	195 – 210
Ø B	45	70	95	125	172
Ø C	120	145	160	195	240
D	35	35	35	35	35
Weight in g	90	115	150	200	340
Mounting ring					
Type	EBR 75/80	EBR 100	EBR 125	EBR 160	EBR 200
Ref. no.	0952	0953	0954	0955	0956
for DN (mm)	75/80	100	125	150/160	200

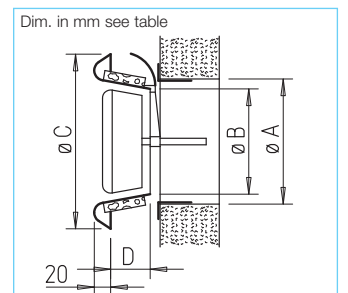



■ Operation

For air supply to any room especially where ventilation system components of non flammable materials are required. Suitable for low and high air flow speed. Low noise characteristic.

■ Advantages

- High-quality metal design, aerodynamically shaped for low sound levels.
- Large cover with optimised height of the inlet ring avoids marking of decor.
- Quick mounting in ceiling and wall without tools.
- Plaster and difference compensation for unevenness, differences in diameter or ducting that has been too deeply plastered.
- Spring mounting clamp offers a direct insertion in ducts or walls up to approx. 20 mm size without an additional mounting ring.

■ Design

Metal construction protected against corrosion by a high quality epoxy paint in white. The foam strip fitted around the valve provides an air tight connection and avoids air leakage and dis-colouration around the valve.

■ Delivery

Each valve is separately supplied in a polybag.

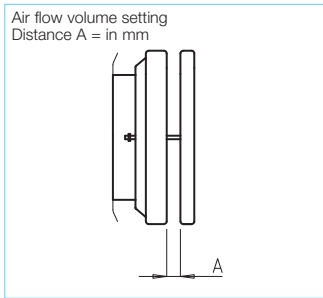

■ Accessories

For installation in ducting, walls or thin panels a mounting ring may be required (see table).

■ Installation

Set valve to required air flow volume according to the diagram. The distance 'A' is given in mm from the 0 point. Then simply press valve into wall or ducting. For an even air flow a straight duct of approximately 300 mm is required.

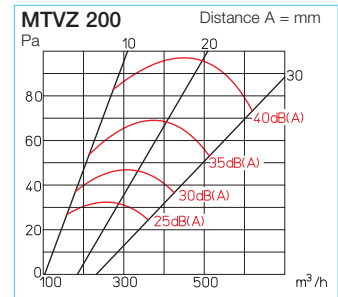
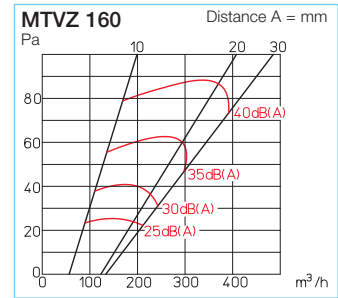
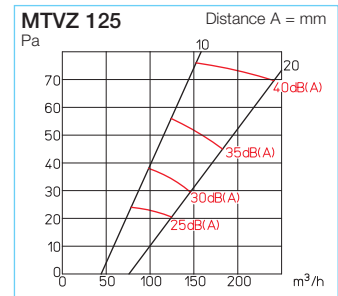
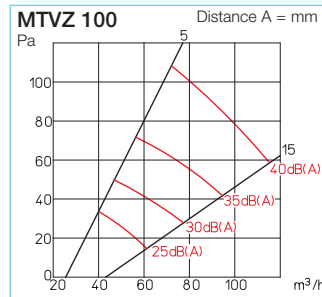
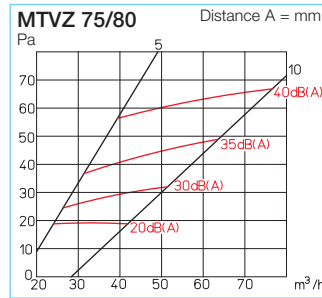

■ Performance data

These diagrams show the relationship between air flow volumes, resistances and sound levels at various adjustments of the distance "A" in mm.

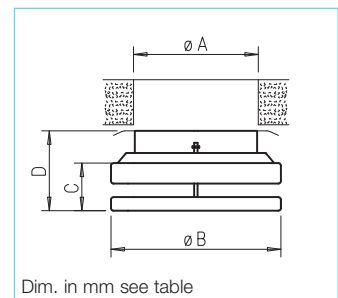

Dim. in mm see table

Ordering data					
Type	MTVZ 75/80	MTVZ 100	MTVZ 125	MTVZ 160	MTVZ 200
Ref. no.	9603	9604	9605	9606	9607
Dim. in mm					
Ø A	73 – 85	95 – 105	120 – 130	150 – 165	195 – 210
Ø B	108	135	160	195	230
C	26 – 46	26 – 46	26 – 46	26 – 56	26 – 56
D	68	70	70	68	73
Weight approx. g	190	240	300	390	480
Mounting ring					
Type	EBR 75/80	EBR 100	EBR 125	EBR 160	EBR 200
Ref. no.	0952	0953	0954	0955	0956
for DN (mm)	75/80	100	125	160	200

KTVZ



Fig.: Type KTVZ 100 – 200

■ Operation

For air extraction with high and low air flow speeds or resistances.
In all rooms without special fire protection requirements.

■ Advantages

- Installation without tools in seconds.
- Elegant valve plate covering the opening for stepless adjustment. Made from high-quality white polymer, suitable for temperatures up to +100 °C.
- Using a mounting ring avoids dis-colouration of surrounding decor.
- Plaster and difference compensation for unevenness, differences in diameter or ducting that has been too deeply plastered.
- Spring mounting clamp offers a direct insertion in ducts or walls up to approx. 20 mm size without an additional mounting ring.

■ Design

Made from impact resistant white polymers and aerodynamically shaped.
Adjustable air flow via rotating valve plate (volume throughput see diagram).

■ Delivery

Every valve is supplied separately in polybag.

■ Accessories

For installation in ducting, walls or thin panels a mounting ring may be required (see table).

■ Installation

Set valve to required air flow volume through corresponding number of core revolutions according to the diagram. Then simply press valve into wall or ducting. For an even air flow a straight duct of approximately 300 mm is required.

The air flow can be directed in a defined direction through the targeted sealing element, e.g. toward centre of room.

■ Performance data

These diagrams show the relationship between air flow volumes, resistances and sound levels at various core openings.

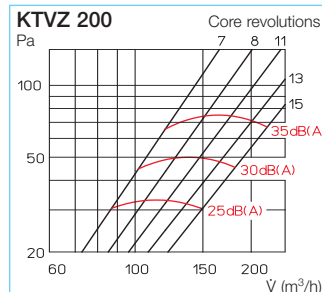
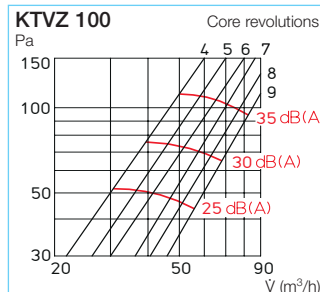
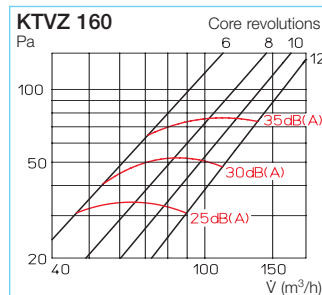
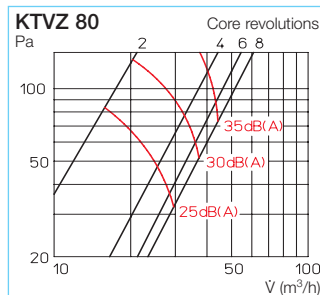
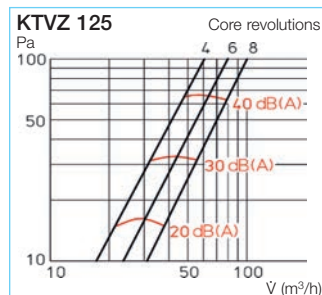

Ordering data					
Type	KTVZ 80	KTVZ 100	KTVZ 125	KTVZ 160	KTVZ 200
Ref. no.	2762	2736	2737	2738	2739
Dim. in mm					
Ø A	70 – 80	95 – 105	120 – 130	145 – 160	195 – 210
Ø B	80	138	170	195	235
Ø C	119	148	180	205	245
D	19,5	17	21	23	22
E	52	47	47	51	56
Weight approx. g	90	100	260	370	600
Mounting ring					
Type	EBR 75/80	EBR 100	EBR 125	EBR 160	EBR 200
Ref. no.	0952	0953	0954	0955	0956
for DN (mm)	75/80	100	125	150/160	200

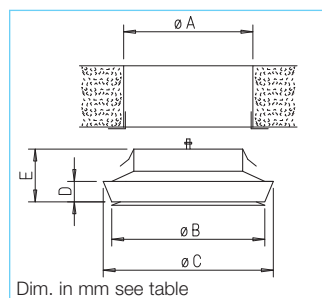

ZTV

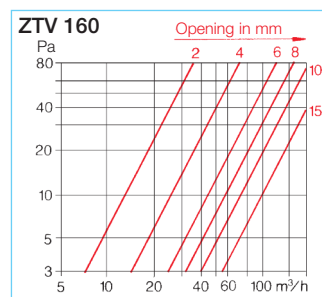
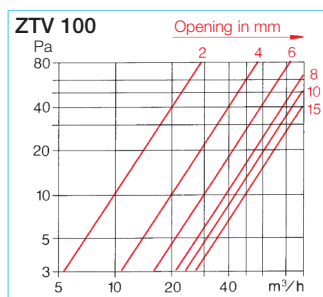
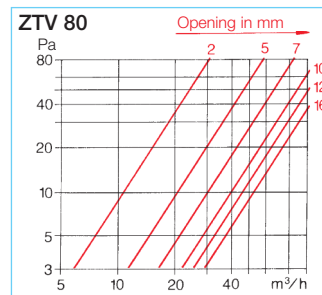
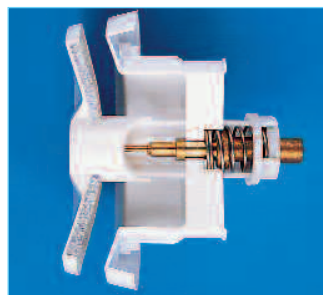

Special features – Operation
 Innovative thermostatic supply air valve for automatic temperature controlled replacement air. Efficiently combines energy savings and permanent ventilation. Permanent control of supply air flow volume with adjustable core for any type of room. Suitable for natural (thermal) and mechanical ventilation as supply air element.

Installation
 ZTV valves can be easily installed in existing supply air openings. They are fixed to ducting by push fit (with rubber gasket) or by three concealed fixing holes in the frame supplied with fixing screws.

Function
 The thermostat operates automatically within a temperature range of -6 °C to +20 °C. Within this range air flow volumes between 0 and 30 m³/h are achieved conforming to DIN guidelines. See performance diagrams on the right. In its standard setting the valve closes completely at outside air temperature of approx. -4 °C. A minimum supply air rate is allowed by the 4 mm wide distance clip. The initial setting of the valve can be changed manually by rotating the centre core. One full rotation equals to a variance of 4 mm gap (see blue marked areas in diagram).

- Advantages**
- Fully automatic, demand-regulated air flow control.
 - Maintenance free, no running cost.
 - Individual air flow volume adjustment by rotating the valve plate.
 - Good sound insulation due to the attenuator built into the valve plate.
 - Attractive, functional design.
 - Wide intake ring reduces wall discolouration.
 - Quick and easy installation.

Design
 The Helios supply air thermostat valves are made of impact resistant, white polymer. Aerodynamically shaped and an attractive design. Insulated coating on inner side of the valve plate to prevent condensation.

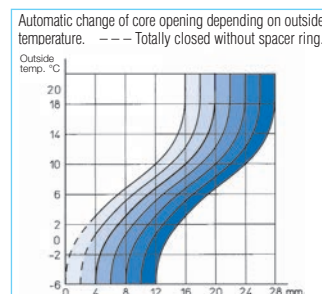
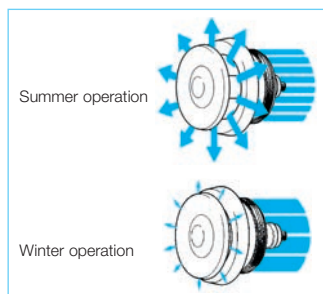

Number of units
 The number of supply air elements necessary is to be defined according to DIN 1946, T.6 depending on the apartment size and wind force (see chart on the right).

Number of units with mechanical demand-based ventilation				
	Apartment size m ²	Number of ZLA / ZLE		Fans
		Extract air (8 Pa)*	Supply air (4 Pa)*	Number/Unit
Hotel room	25 m ²	2	-	1
Apartment	25 m ²	2 (3) **	-	1
Flat	I	2	3 - 4	2
	II > 50, < 80 m ²	3	4	2
	III > 80 m ²	4	5	3
House	up to 120 m ²	4	5	3

* according to DIN 1946, T.6 tab. 10 ** if a kitchenette is also to be extracted

Ordering data			
Type	ZTV 80	ZTV 100	ZTV 160
Ref. no.	0078	0073	0074
Dim. in mm			
∅ A = Duct nominal size	80	100	160
∅ B	77	95	156
∅ C	147	147	207
D	77	77	77
E	49	49	50
Weight approx. g	230	240	370

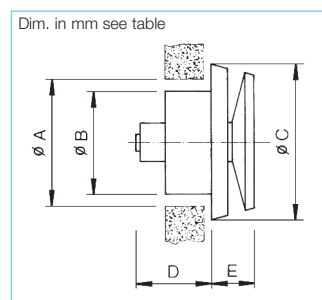

ZLA

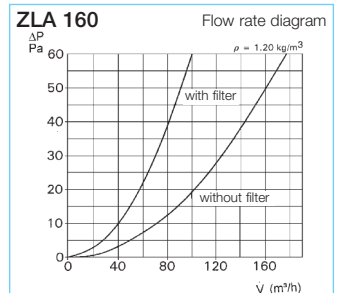
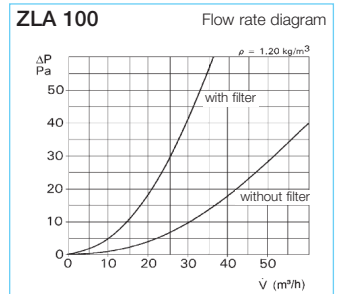
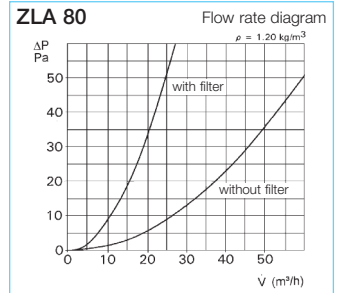
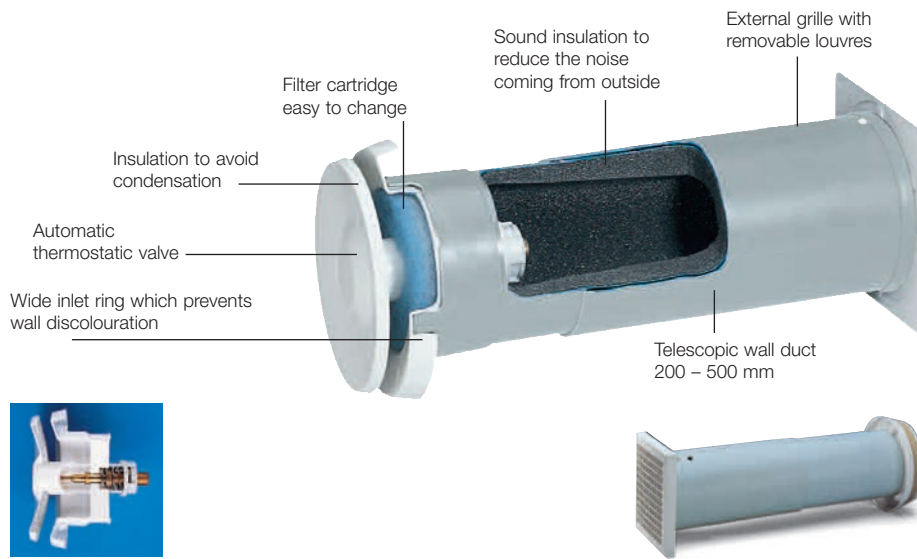

Special features – Operation

Universally adaptable temperature controlled supply air unit. The energy saving, thermostatic supply valve provides a continuous air exchange at highest efficiency. The supply air volume is controlled depending on the outside air temperature, without any electrical connection. The supply air is evenly distributed, filtered (class G 3) and attenuated.

Advantages

- Fully automatic, on demand air flow control.
- Maintenance free, no running cost.
- Individual air flow volume adjustment by rotating the central core.
- Telescopic wall duct, made of polymer for wall thicknesses between 200 to 500 mm.
- High sound insulation via the built-in attenuator.
- Easily removable filter.
- No electrical supply required.
- Quick and easy installation.

Function

The thermostat operates automatically within a temperature range of -6°C to $+20^\circ\text{C}$. Within this range air flow volumes between 0 and 30 m³/h are achieved conforming to DIN guidelines. See performance diagrams on the right. In its standard setting the valve closes completely at outside air temperature of approx. -4°C . A minimum supply air rate is allowed by the 4 mm wide distance clip. The initial setting of the valve can be changed manually by rotating the centre core. One full rotation equals to a variance of 4 mm gap (see blue marked areas in diagram).

Installation

Suitable for wall or ceiling openings. Telescopic duct should be inserted from outside and the cover grille should be screwed on. Duct to be cleaned and the valve to be inserted from inside.

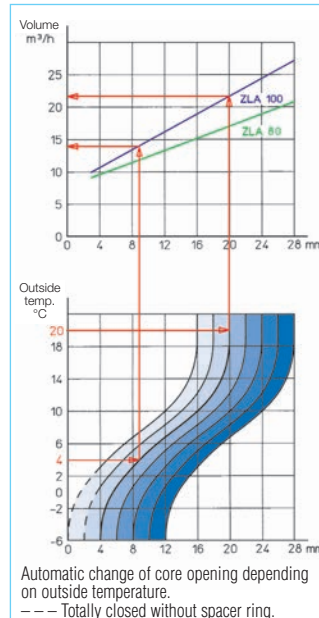

Note

The number of supply air units is to be defined according to DIN 1946, T.6 (see chart on the left page).

Performance data

The air flow volume depending on pressure difference is determined by the opening gap of the valve plate. The performance values can be seen from the diagrams above.

Accessories

Spare filters class G 3
Contents: 10 pcs.

Type ELFZ 80 Ref. no. 0339

Type ELFZ 100 Ref. no. 0340

Type ELFZ 160 Ref. no. 0341

Ordering data

Type	ZLA 80	ZLA 100	ZLA 160
Ref. no.	0214	0215	0216
Volume max. with filter m ³ /h	25	35	100
Duct nominal size (mm)	80	100	160
Wall penetration \varnothing mm	96	115	175
$\varnothing A$ mm	147	147	207
B mm	49	49	50
C mm	260–500	260–500	260–500
D mm	107	140	190
E mm	3	15	24
Weight approx. kg	0,7	0,8	1,6
Sound insulation value $D_{n,e}$ 30 to 35 dB (depending on installation or wall thickness; corresponds to double glazing acc. to VDI 2719 protection class 2 or 3).			

Dim. in mm see table

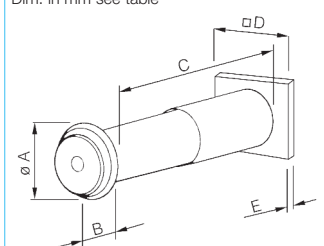

ZLE

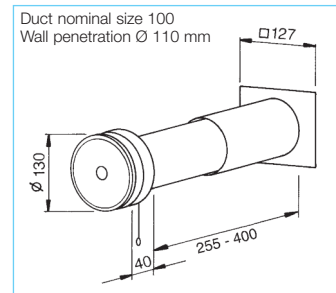
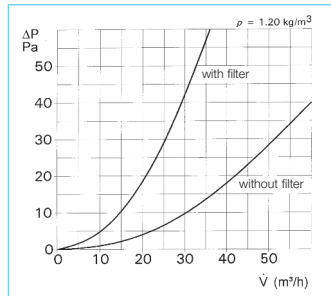

Special features – Operation

Manually operated supply air element for any kind of room. The air flow volume can be adjusted through a four step ratchet mechanism using a pull cord. The supply air is evenly distributed, filtered (class G 3) and attenuated.

Advantages

- Permanent intake air reduces draughts.
- Adjustable air volume controlled by adjusting the valve plate.
- Simple control via pull cord.
- No electrical supply required.
- Wide intake ring reduces wall discolouration.
- Telescopic wall duct, made of polymer for wall thicknesses between 255 to 400 mm.
- Good sound insulation with the built-in attenuator.
- Easily removable filter.
- Quick and easy installation.

Installation

Simple installation in wall openings. Insert the telescopic duct from outside, adjust to thickness of wall and render. Push in rain repellent grille from outside, snap lock fixing or can be screwed with masonry plugs. Insert valve from inside. If placed near radiators the supply air is preheated during the cooler periods. Ensure that valve is accessible for filter change.

Design

ZLE comes as a complete unit including:

Valve

Attractive, unobtrusive design made of high quality white polymer. Incorporating a pull cord for three core positions. Insulated coat on inner valve to prevent condensation.

Telescopic wall duct

Two liners, made of impact resistant polymer.

Attenuator

To reduce air sound levels from outside.

Air filter

For clean and dust free air supply (class G 3), replaceable.

Outside wall grille

Fixed, rain repellent, made of UV-stable polymer in white.

Filter change

Easy, without any tool kit. Can be maintained by removing the valve.

Performance data

The air flow volume depending on pressure difference is determined by the opening gap of the valve plate. The performance figures are shown in the diagram above. Sound insulation rate: $D_{n,e}$: 30–35 dB (depending on installation and wall thickness; comparable with double glazing class 2 or 3).

Number of units

The number of required supply air elements is to be defined according to DIN 1946, T.6 independant to the apartment size and wind force (see the following chart).

Type ZLE 100 Ref. no. 0079

Accessories

Spare filter class G 3

Type ELF/ZLE 100 Ref. no. 0338

Contents = 10 pcs.

Number of units with mechanical demand-based ventilation				
	Apartment size m ²	Number of ZLA / ZLE		Fans
		Extract air (8 Pa)*	Supply air (4 Pa)*	Number/Unit
Hotel room	25 m ²	2	–	1
Apartment	25 m ²	2 (3) **	–	1
Flat	I 50 m ²	2	3 – 4	2
	II > 50, < 80 m ²	3	4	2
	III > 80 m ²	4	5	3
House	up to 120 m ²	4	5	3

* according to DIN 1946, T.6 tab. 10 ** if a kitchenette is also to be extracted

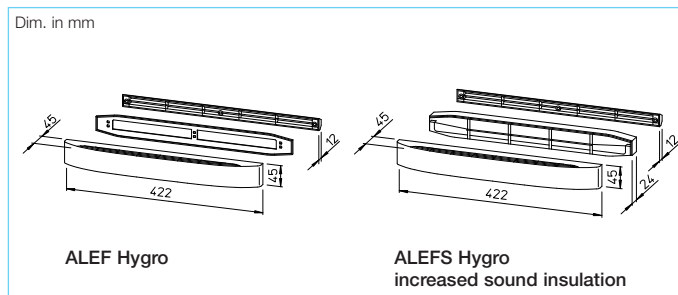
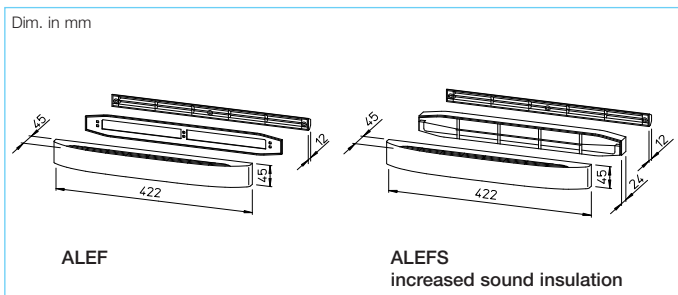

Air flow volume elements ALEF with air flow volume control / limitation, to install in window frames / casements.

Operation

The window element flow is directly related to the differential pressure and supplies the outside air to living rooms and bedrooms. Simple installation, is also suitable for retro-fitting.

Design

Ready-to-install unit, contains inner facade with an automatic air flow volume delimiter, installation plate and cover strip. All parts are made of high quality, white polymer. The models ALEFS have an acoustic element for an increased sound insulation.

Function

Due to the negative pressure of extract air in the kitchen, bathroom and toilet, the element allows a certain amount of air flow volume to enter in the living / bedrooms from outside (see diagram).

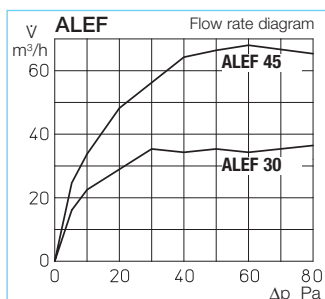

Humidity controlled air flow volume elements ALEF Hygro with air flow volume control / limitation to install in window frames / casements.

Operation

Window elements that allow a controlled air flow volume, dependent on the humidity level in the room, to enter in the living / bedrooms.

Ideal in combination with humidity controlled extract fans. Simple installation, is also suitable for retro-fitting.

Design

Ready-to-install unit, contains inner facade with an automatic air flow volume delimiter, installation plate and cover strip. All parts are made of high quality, white polymer. The models ALEFS Hygro have an acoustic element for an increased sound insulation.

Function

Due to the negative pressure of extract air in the kitchen, bathroom and toilet, the element allows a certain amount of air flow volume, which depends on the humidity level in the room, to enter in the living / bedrooms from outside (see diagram).

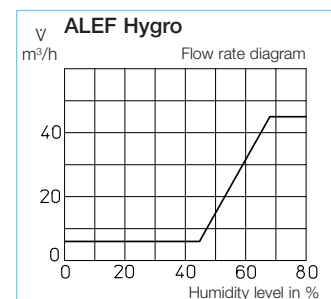

Installation

In wooden, polymer and metal window frames. Openings by means of milling groups or holes in the upper frame. Simply screw the cover strip to the installation plate and clip the inner facade on.

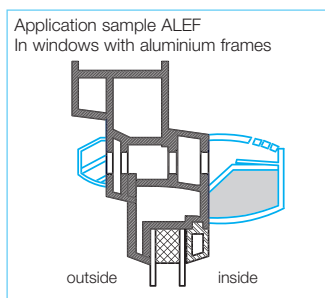

Installation

In wooden, polymer and metal window frames. Openings by means of milling groups or holes in the upper frame. Simply screw the cover strip to the installation plate and clip the inner facade on.

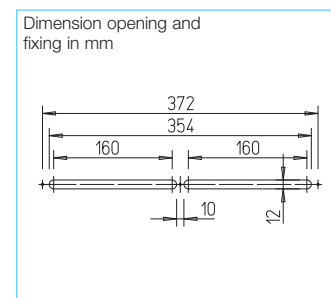

Ordering data	Air flow volume elements to install in window frames			
	ALEF with air flow volume control and limits		ALEFS similar to ALEF, extra attenuation	
Type	ALEF 30	ALEF 45	ALEFS 30	ALEFS 45
Ref. no.	2100	2101	2102	2103
Air flow vol. m³/h	30	45	30	45
Sound insulation D _{n,e} in dB (A)	39	37	41	39
Weight approx. g	190	190	210	210

Ordering data	Air flow volume elements to install in window frames	
	ALEF Hygro – with humidity controlled air flow volume control and limits	ALEFS Hygro similar to ALEF with extra attenuation
Type	ALEF 6/45 Hygro	ALEFS 6/45 Hygro
Ref. no.	2056	2057
Air flow vol. m³/h	6/45	6/45
Sound insulation D _{n,e} in dB (A)	37	39
Weight approx. g	200	220